

## INSTALLATION GUIDE

Please take a few minutes to read through this guide before getting started.

### 1. Overview

Typical Sliding Wardrobe Door Layout

- A** Frame - Top/Ceiling Liner (optional)
- B** Top Track
- C** Frame - Wall Liners (optional)
- D** Sliding Doors
- E** Bottom Track
- F** Frame - Bottom/Floor Liner (optional)
- G** End Panel (optional)

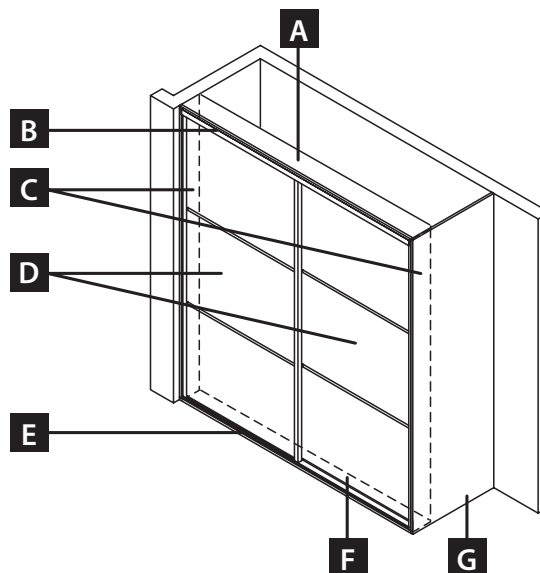

### 2. Measuring

Please refer to the comprehensive measuring guide on our website:

[www.wardrobedoorsdirect.co.uk/measuring-guide](http://www.wardrobedoorsdirect.co.uk/measuring-guide)

Please measure carefully both the opening height and width in a minimum of three places. Please provide the smallest measurement for the height and for the width. If the height or width measurements vary by more than 10mm we recommend constructing a simple frame using wall liners and top and bottom liners which can be purchased through our website:

[www.wardrobedoorsdirect.co.uk/extra-items](http://www.wardrobedoorsdirect.co.uk/extra-items)

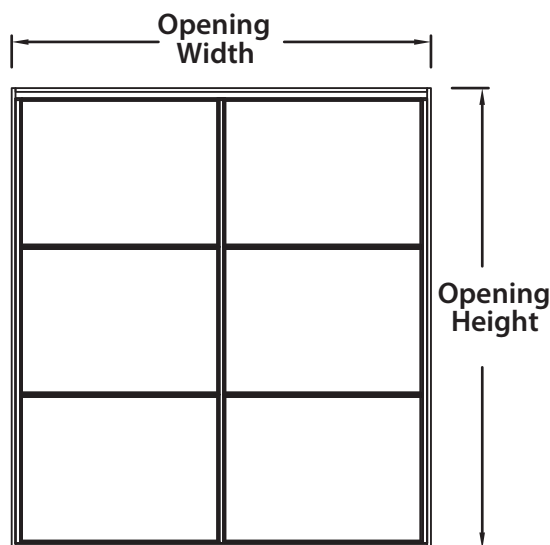

### 3. Tools & fixings you will need

#### Tools

- Electric Drill
- Screwdriver
- Hacksaw (recommended 32 tpi blade to trim track sets)
- Electric Jigsaw\* / Handsaw\*
- Spirit Level
- Set Square
- Bradawl
- Plumb Line
- Metal Drill Bits (4mm diam.)
- Wood Drill Bits (2mm diam.)
- Wood Drill Bits (4mm diam.)
- Masonry Drill Bits (8mm diam.)
- Countersink Drill Bit
- Tape Measure

\*with appropriate blade for cutting MFC.

#### Fixings / Materials

- Masonry Wall Plugs & Screws
- MFC Fixing Screws/Cover Caps
- Timber Fixing Screws
- Corner Blocks and/or Timber Battening (if installing end panels or interior shelving/partitions)
- Packers
- Sand Paper
- Masking Tape

## 4. Constructing the frame

### 4.1 Planning the area

**IMPORTANT** - Before beginning construction check all relevant dimensions carefully. Check the wall and under-floor areas to avoid damaging water or central heating pipes and electric cables.

### 4.2 Constructing a frame (optional)

Constructing a frame will help with levelling, ease of fixing and will increase stability of the finished wardrobe. Wall liners and top and bottom liners are available through our website in kits of 2, 3, 4, 5 or 6 pieces depending upon the size of wardrobe and your order. Any aperture wider than 2620mm will need two floor/ceiling liners butted together.

**Note:** For installations over carpet or where carpet is going to be laid we recommend you use the liner system.

### Skirting boards and coving/cornices

Before commencing installation decide which option you prefer with regard to existing skirting boards. The wall liner thickness (18mm) is generally the same as the projection of the skirting board; therefore if you wish to avoid cutting the skirting board the wall liner can be positioned above the skirting to the ceiling (see illustration **a**). Alternatively, if you wish to run the wall liner from floor to ceiling then you must remove the skirting board at the correct position allowing a tolerance for the liner supplied (see illustration **b**). If you have a coving or cornice at ceiling level and you have ordered your system to fit to the ceiling height you must also remove the corresponding portion of the coving with clearance to allow for the top liner to finish at ceiling level.

### Cutting and drilling the wall liners and top and bottom liners

Cut the wall liners and top and bottom liners to size, less 2mm. Drill 5mm holes centrally in the width of the liners, approximately 150mm from each end and space out the remaining screw holes evenly at a maximum of 500mm centres (see illustration **c**). In the top and bottom liners countersink the screw holes to allow the top and bottom tracks to be fitted flush.

**TIP** When cutting the wall liners and top and bottom liners to length use masking tape along the cut lines to prevent the laminate surface from chipping. Before cutting, score with a sharp knife along the line you are going to cut. Carefully remove the tape after you have finished cutting the liners to length.

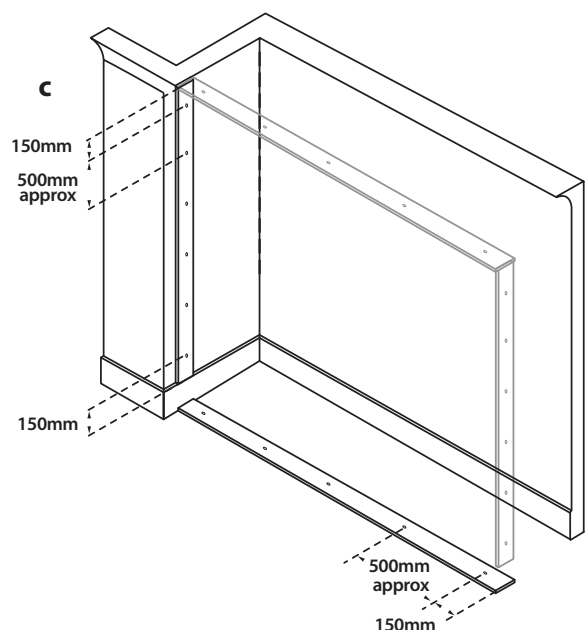
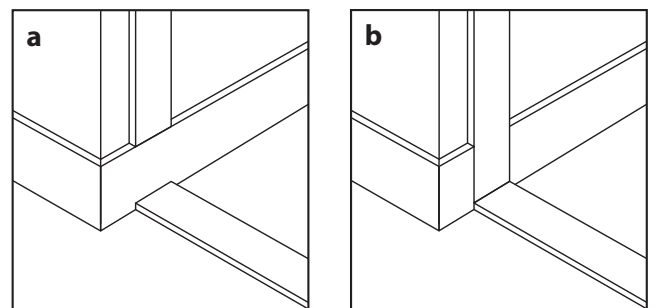
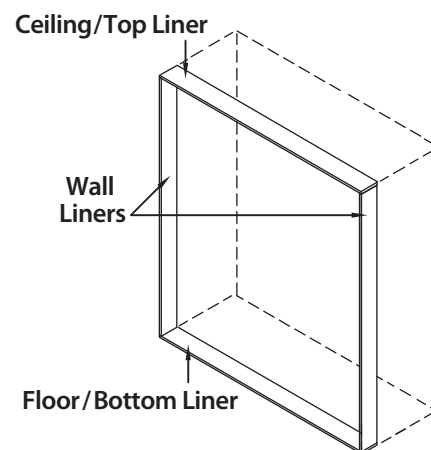
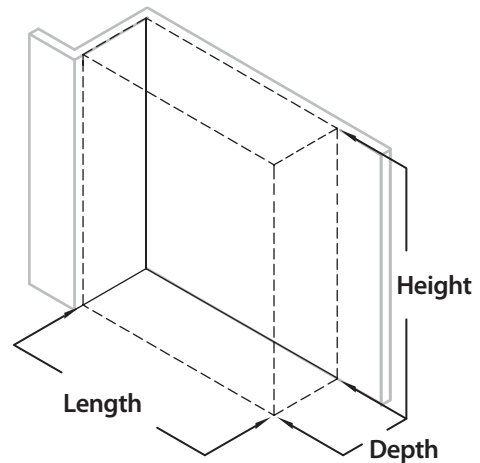

### Fitting the top and bottom liners

Place the floor liner in position. It is essential for the proper running of the doors that the bottom track is perfectly level; therefore, check this carefully using a spirit level. When you are satisfied fix the liner to the floor (using packers where necessary) with countersunk screws, ensuring the heads finish flush with the face of the liner. Repeat with the ceiling liner. If screw fixing use the appropriate fixing plugs depending upon whether the ceiling is lath and plaster or plasterboard.

### Fitting the wall liners

Place the first wall liner into position. Check with a spirit level that it is vertical and pack away from the wall if necessary to ensure it is plumb. If using plugs and screws secure it to the wall ensuring the screw heads finish flush with the face of the wall liner. Repeat with the second wall liner. As an alternative to drilling and screwing the wall liners, so as to provide a neater final appearance, a grab adhesive (eg. No More Nails, Pink Grip) can be used to fix these to the walls. Make sure to follow the manufacturer's guidelines and check all levels again after final fixing.

**Note:** Any screw heads visible after fixing the top and bottom liners will be covered by the tracks when they are fitted so there is no requirement to disguise these.

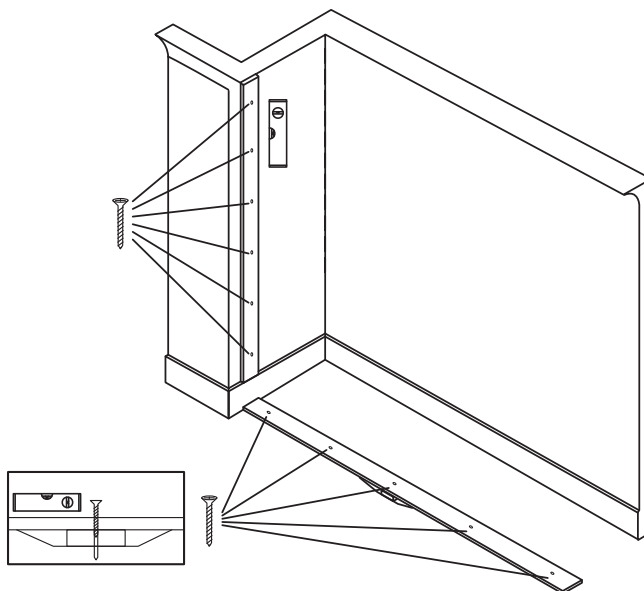

### 4.3 Fitting an End Panel (optional)

If you are not using the full width of an alcove, or constructing your wardrobe from a corner in the room, you will need to add an end panel. This can be attached to the floor, ceiling and back wall using fixing blocks, or with timber battening and screws (not supplied). The end panel replaces the requirement for one of the wall liners and therefore needs careful positioning and cutting to size so that it fits flush with the ceiling and floor liners.

#### Step 1

Measure from the face of the wall your width dimension **(A)** to the **outside face** of the end panel, and mark the position on the back wall with a pencil. At this same position measure the height dimension from floor to ceiling **(B)** on the back wall and also at a position to align with the front of the end panel **(C)**. If both dimensions are the same cut down the end panel to this size, minus 2mm. If there is a significant difference between the sizes cut the end panel to match the shape of the ceiling.

**TIP** If you are creating a wardrobe which which will need a top panel adding (see 4.4), make sure the end panel is taller than the height of the frame by 18mm so that the top panel will fit flush with the top edge of the end panel - see top illustration.

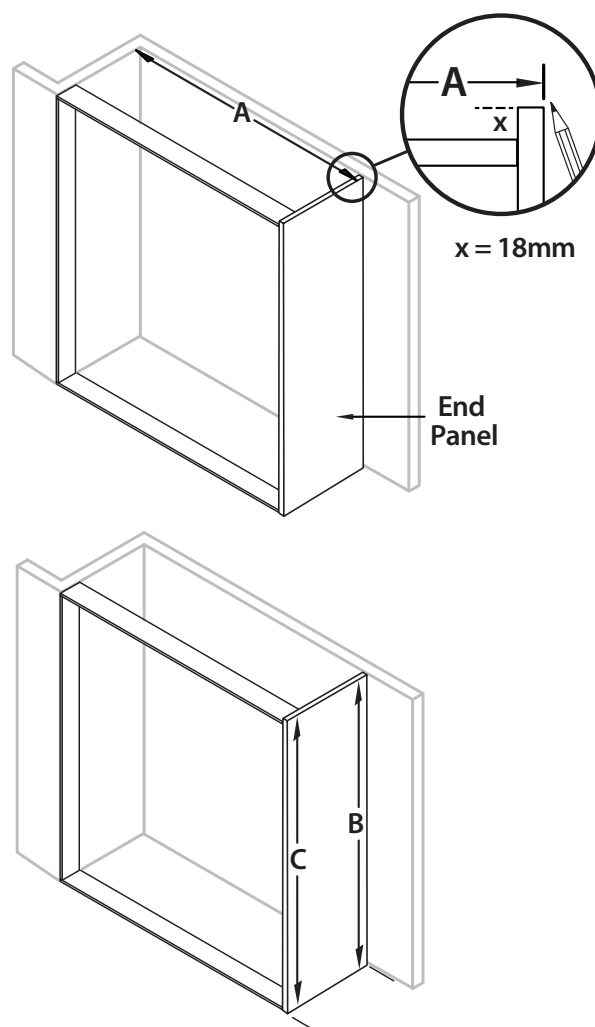

## Step 2

To accommodate skirting boards either:

- cut to shape the end panel over the skirting board (see illustration **a**) or;
- remove a section of the skirting board to match the thickness of the end panel and slide the end panel into the gap so that it butts up against the back wall (see illustration **b**).

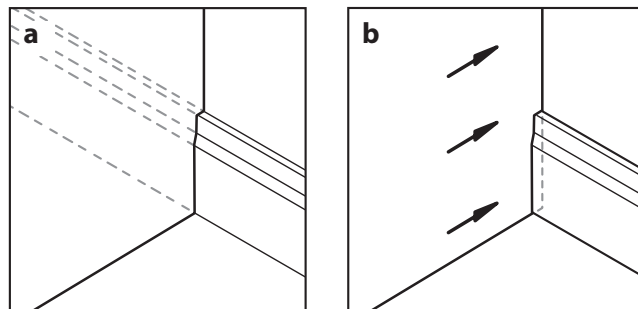

## Step 3

Using fixing blocks, secure them flush with the edge of the end panel, two at the top, two at the base and four to the long wall edge. Place the panel against the back wall, check for plumb with a spirit level and secure through the blocks with wall plugs and screws. Use No 8 x 13mm screws into the end panel so that they do not come through the other side. Use No 10 x 32mm screws for fixing into the wall.

## Step 4

Continue fitting the bottom track liner and wall liner as previous instructions, (section **4.2**) installing between the end panel and the wall/skirting board.

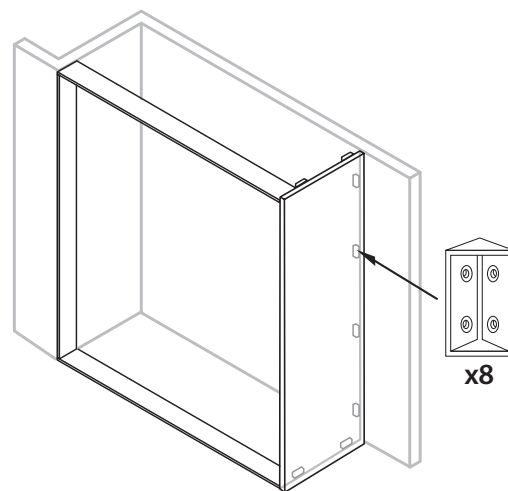

## 4.4 Fitting a Top Panel (optional)

If you are not using the ceiling of the room to create the ceiling of your wardrobe, you will need to add a top panel. This can be attached to the top liner, the side panel and back walls using fixing blocks, or with timber battening and screws.

**TIP** *If you are using screws to fix the top panel to the top liner of the frame, make sure the screw ends do not protrude through to the underside of the top liner as this will spoil the appearance and may prevent the top guide track being attached properly.*

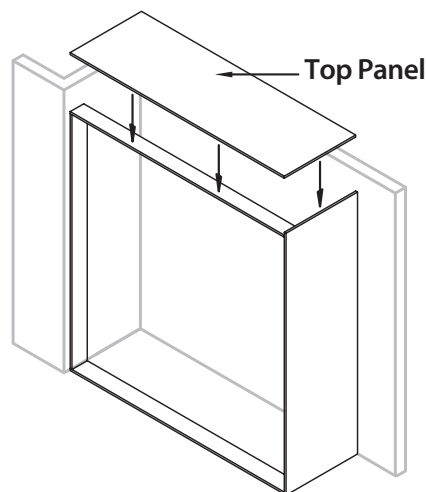

## 4.5 Full height End Panel and Ceiling Infill (optional)

As an alternative to a top panel, a ceiling infill panel can be used to make up the depth between the top of the frame and the ceiling of your room. This can be fixed to the top liner of the frame, the wall, end panel and ceiling using fixing blocks or with timber battening and screws. Liners (100mm width), shelves (500mm width) or end panels (640mm width) cut down to size can be used to create infill panels, depending upon the height reduction required.

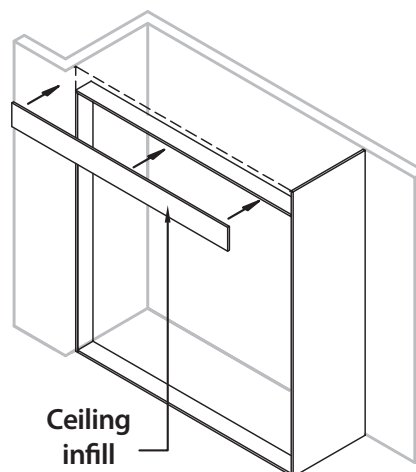

## 5. Installing the tracks

### 5.1 Cutting the top and bottom tracks

Carefully measure the width of your opening at the top and bottom. Deduct 2mm from each measurement and cut your top track and bottom track to the correct length with a hacksaw.

For positioning of tracks at Section **A/A** please see the next step **5.2**.

**TIP** To assist when cutting the top track insert 50mm x 38mm (2" x 1½") wood blocks into each channel for support - see illustration below. To make it easier to mark the position for cutting and to prevent the saw blade skidding it is also advisable to wrap masking tape around the track before commencing cutting. Once the track has been cut, remove the tape.

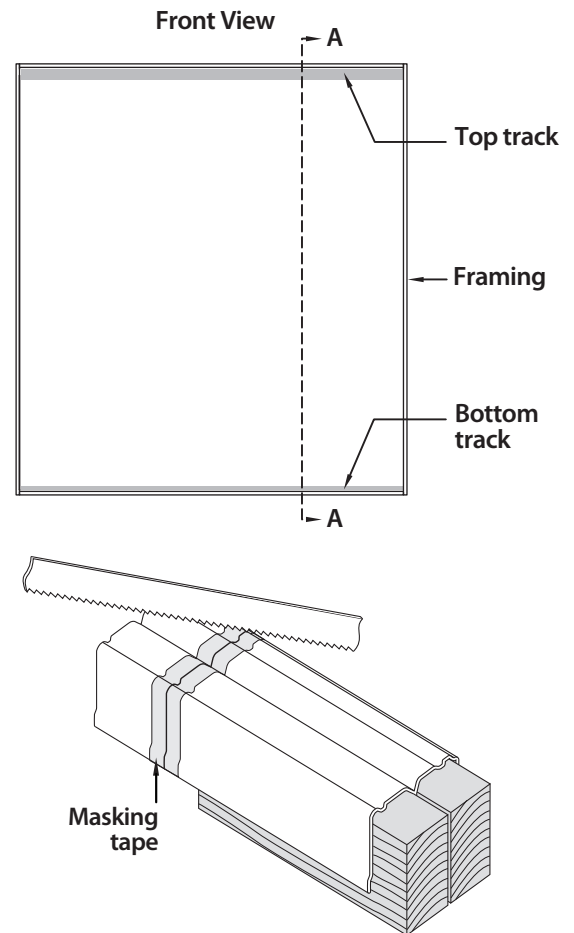

### 5.2 Positioning and installing the top track

Mark on the track, inside both channels, where the screws will be fixed. Set the holes approx. 80mm from each end of the track and space the remaining holes evenly along the length of each channel, approx. 500mm apart - see top illustration. Drill 4mm holes through the top track at the points you have marked. Then, holding the top track in position against the top liner (or ceiling), with the front face flush with the front of the top liner, mark the positions of these holes on the top liner (or ceiling). Use a bradawl or 2mm drill bit to make pilot holes in the top liner before screwing the top track in place. (If fixing the track directly to the ceiling make sure to use suitable plugs). Take care not to overtighten the screws as this can distort the track.

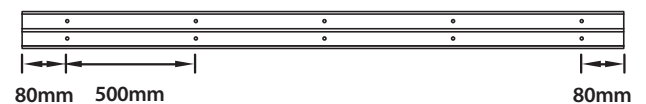

**TIP** Before marking the positions for the screw holes and drilling your tracks, stick short lengths of masking tape to the areas to be marked/drilled as this will help you to mark the position for drilling more easily and will prevent the drill bit skidding and scratching the surface of the rails.

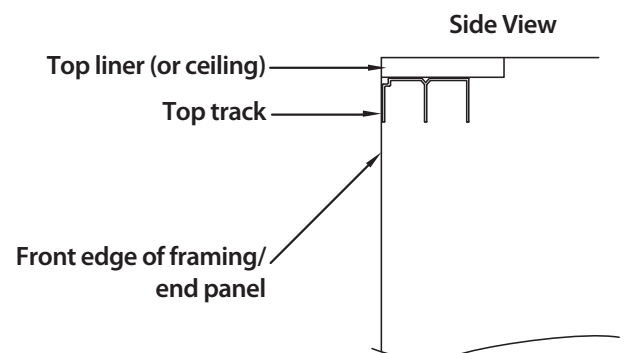

### 5.3 Positioning and installing the bottom track

To ensure the correct positioning of the bottom track use a plumb line from the front edge of the top track and mark three points on the bottom liner (or floor). Draw a straight line through these three points using a rule. Depending upon whether your bottom track is steel or aluminium please refer to the appropriate section below for drilling and positioning.

## 5.4 Steel track

Position the bottom track **19mm** behind the line you have marked (see illustration **a**). Mark on the bottom track, along the centre line where the screws will be fixed. Set the holes approx. 80mm from each end and space the remaining holes evenly at approx. 500mm intervals. Drill 4mm holes through the bottom track at the points you have marked and then mark these positions on the bottom liner (or floor) with the bottom track positioned on the line you drew in the step above. Fix the bottom track using the same method as used to fix the top track. As an alternative to screw fixing, the top track may be fixed using a suitable silicon contact adhesive.

### a) Steel track

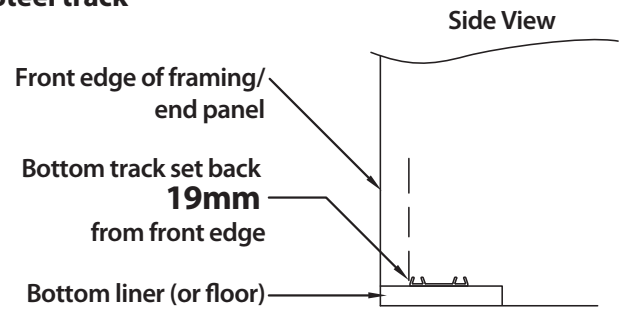

## 5.5 Aluminium track

Position the bottom track **8mm** behind the line you have marked (see illustration **b**), ie. the bottom track needs to be central to the top track. Mark on the bottom track, along the centre line where the screws will be fixed. Set the holes approx. 80mm from each end and space the remaining holes evenly at approx. 500mm intervals. Drill 4mm holes through the bottom track at the points you have marked and then mark these positions on the bottom liner (or floor) with the bottom track positioned on the line you drew in the step above. Fix the bottom track using the same method as used to fix the top track.

### b) Aluminium track

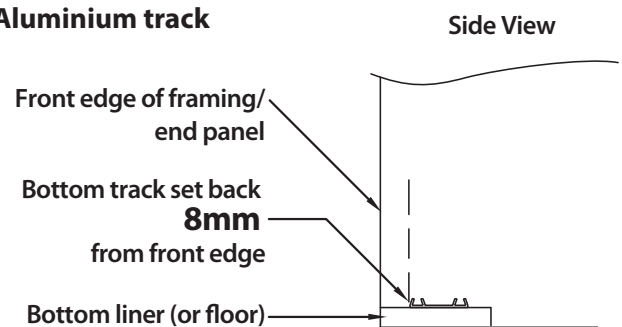

**IMPORTANT** - Please slide door positioners into the aluminium bottom track before fixing to the floor liner (see illustration **c**). Door positioners are not required for a two door system if the bottom track is level. Refer to section **8.2** for final positioning.

### c) Aluminium track door positioners

Insert door positioners into aluminium bottom track before fixing in place.

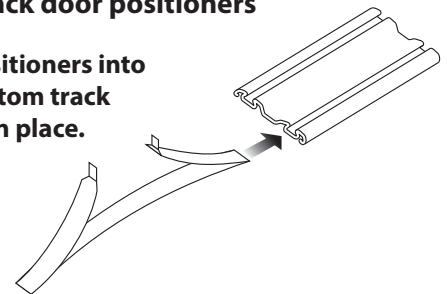

## 6. Installing the doors

### 6.1 Doors

**Note:** Depending upon the material and size of your doors they can be very heavy. It is advisable to have another person to help you lift and install the doors.

Install the rear door(s) first. Tilt each door as shown and fully insert the top of the door into the rear channel of the top track (**A**). Taking care not to damage the bottom rollers, align them with the bottom track (**B**) and slowly lower the door, letting the rollers snap into the track grooves.

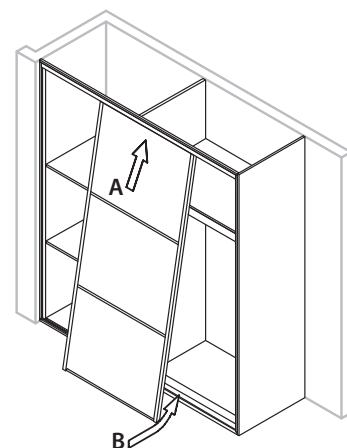

Repeat the process with the front door(s), using the front channel and front bottom track. For multi door systems alternate the doors on the tracks.

**TIP** *By default the bottom rollers are set to the lowest position so you may have to adjust these to raise the doors up. If the doors are set to the lowest position take care not to scratch the bottom track when testing the slide.*

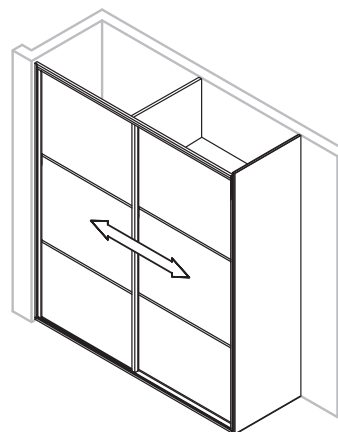

## 6.2 Checking movement

Make sure the doors and tracks are positioned parallel and level. Check all doors travel smoothly along the entire width. Follow the next steps to make the final adjustments.

# 7. Door adjustment

## 7.1 General

Although your doors have been manufactured to the dimensions you have specified some minor adjustment may be required so that they a) run smoothly within the top rails; and/or b) engage correctly with the soft-close activators if your doors have been fitted with soft-close mechanisms (see section 9). The method for door height adjustment varies depending on whether you have installed steel frame doors or aluminium frame doors – see next steps.

## 7.2 Steel frame - bottom roller

Make sure each door sits flush with the wall and/or other doors by raising and lowering the left and right sides of the door. The door level above the bottom track can be raised or lowered by adjusting the screw on the bottom rollers, using a screwdriver – see illustration **a**.

- To move the doors down – turn clockwise
- To move the doors up – turn anti-clockwise

## 7.3 Steel frame - top roller

Usually, the top rollers should not require any adjustment; however, they can be adjusted if required by sliding the pin up or down in the slot – see illustration **b**.

**a)**

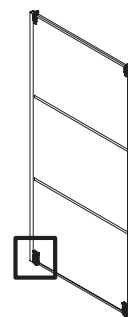
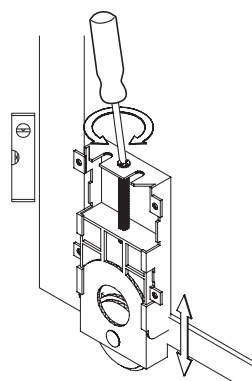

**b)**

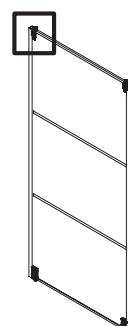
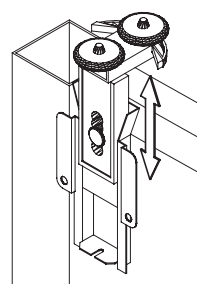

## 7.4 Aluminium frame - bottom roller

The bottom roller can be adjusted using the allen key provided by turning the adjustment bolt through the hole in the side profile – see illustration **c**.

- To move the doors down – turn anti-clockwise
- To move the doors up – turn clockwise
- After adjustment, plug the hole with the plastic hole covers provided.

c)

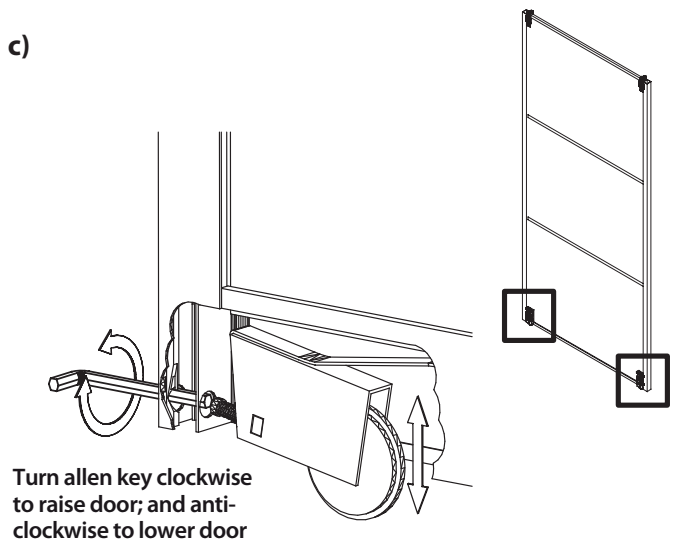

## 8. Fixing the door positioners\*

### 8.1 Top track door positioners (steel track only)

With the doors closed scribe in pencil a vertical line on the central divide of the top track at the centre point of where the door roller rests. Place the door positioner central to this line and mark the fixing position through the hole on the door positioner. Use a self tapping screw to fix the door positioner in place inside the top track against the central divide. Before final tightening of the screw adjust the distance of the door positioner closer to or further away from the central divide so that the guide wheel will sit comfortably into the recessed area when the door is in the closed position.

For each door in your arrangement follow this method for placing and securing the door positioners. Refer to the diagram at the top of page 9 for the correct placing of door positioners in multi-door arrangements.

\* **Note:** Door positioners do not require fitting on 2-door arrangements or when the door closes against a wall or a wall liner.

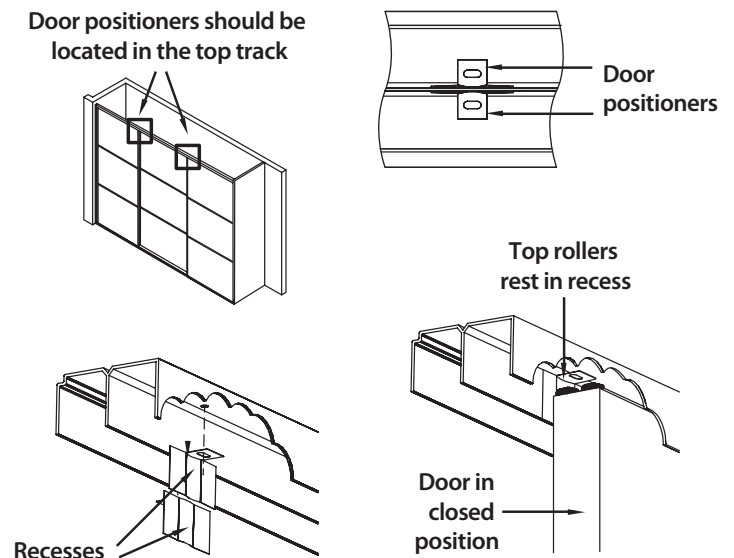

### 8.2 Bottom track door positioners (aluminium track only)

**IMPORTANT:** Aluminium door positioners need to be inserted into the bottom track **before** fixing it to the floor or bottom liner - see section **5.5 Aluminium track**.

Pull the doors to the closed position and mark on the bottom track the centre point between the doors. Slide the door positioners along the front and rear channels until the centre of each is at the centre point you have marked on the track. No screwing is necessary. For multi-door arrangements see the diagram opposite for correct placing of the door positioners.

\* **Note:** Door positioners are not necessary for a 2-door arrangement unless the bottom track is not level.

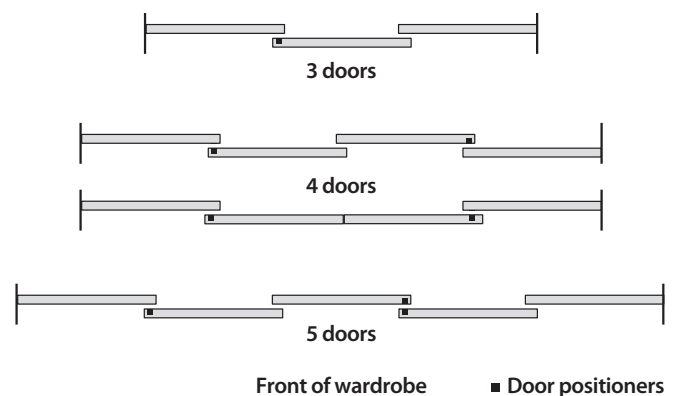



## 9. Soft-close mechanisms \*

If you have ordered soft-closers\* these will come pre-fitted to the top of your wardrobe doors. Each soft-close mechanism requires a wall liner or wall to work against and so the maximum number of doors possible in a two-track arrangement using soft closers is four (two front doors and two rear doors). In 5-door arrangements the central door cannot be fitted with a soft-close mechanism.

The illustration **a** opposite shows the positions of the soft-close mechanisms, depending upon which door arrangement is ordered.

To enable the doors to close softly you will also need to fix a 'soft-close activator' to the top track for each soft-close mechanism fitted. The correct number of soft-close activators will be delivered with your doors. For correct positioning/fixing of the soft-close activator please see step **9.2**.

### 9.1 Priming the soft-closer mechanism

Each of the soft-close mechanisms fitted needs to be 'primed' so that they will work correctly when used.

Check the position of the green plastic engagement block within the slot in the top of the soft-closer – see illustration **b**.

- If it is in position **A** the mechanism needs to be primed;
- if it is in position **B** the mechanism is already primed.

If the mechanism needs to be primed you can use the green plastic peg on the soft-close activator to do this – see illustration **c**. Locate the activator's peg into either one of the two slots in the engagement block and pull the block along the slot in the direction of the two green plastic guide wheels until the activator can be pulled free of the soft-close mechanism. Take care in doing this as when turned over, the raised metal tabs at the edges of the activator can be quite sharp when gripped.

When the engagement block can be seen to be at position **B** the soft-close mechanism is primed correctly.

### 9.2 Fitting the soft-close activators

To enable the soft-close mechanism to operate when closing your doors an activator needs to be fixed into the top track. You will need to fit an activator for every soft-closer that is fitted to your doors and if you have doors which run in both the front and back channels you will need to fit activators into both of these channels.

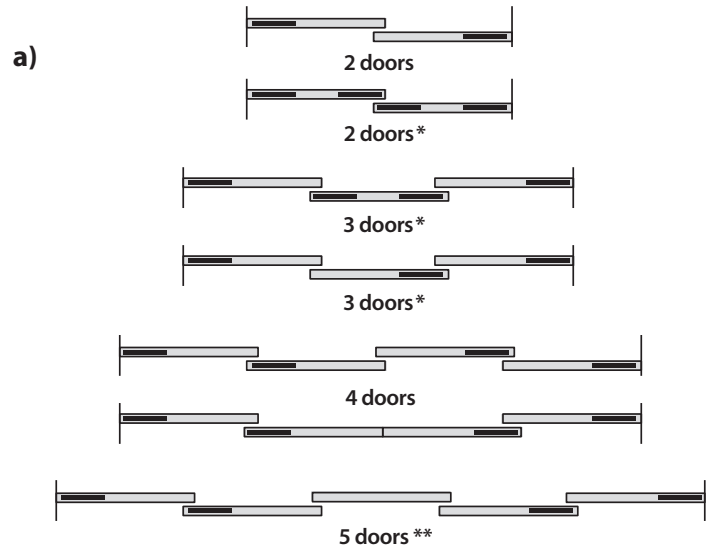

\* In 2-door or 3-door arrangements where two soft-closers are fitted to each end of a single door, the door must be a minimum width of 850mm to allow both soft-closers to be installed. Doors fitted with a single soft-closer must be a minimum width of 500mm.

\*\* In 5-door arrangements the central door cannot be fitted with a soft-close mechanism.

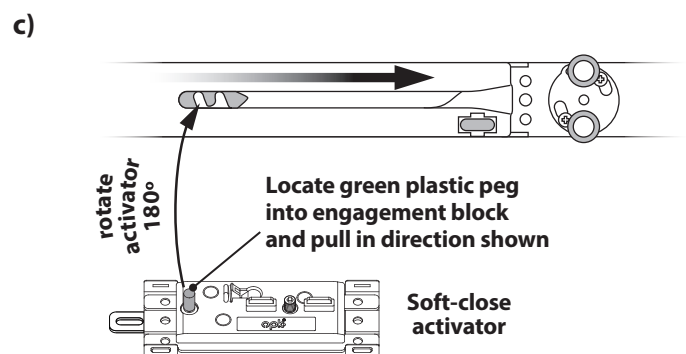
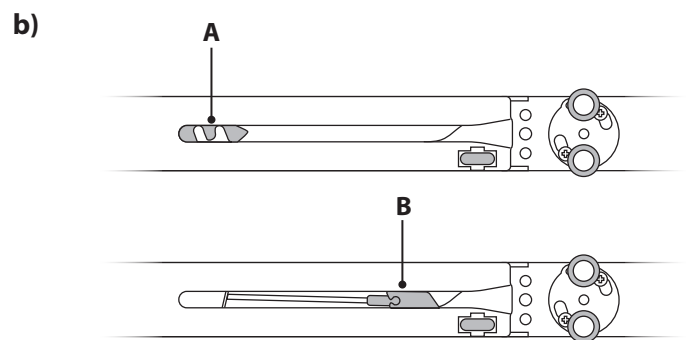

\* Please note, soft-close mechanisms are optional extras that will need adding to your order.

Depending on whether you have ordered aluminium- or steel-framed doors or doors from the Minimalist or Shaker ranges, please follow the appropriate instructions below for fitting the soft-close activators:

### 9.2.1 Steel top track

Using a 3mm diameter bit for drilling metal, drill **two holes** into the appropriate channel of the the top track, along its centre line – the first **140mm** from the end of the track and the second **226mm** from the end of the track – see illustration **d**. (If you are fitting soft-closers to doors which run in front and back channels you will need to fit activators into both channels.)

A plastic adapter plate is provided which should be placed between the top track and the soft-close activator itself. It helps the activator sit flat in the top track and has locator pegs that help you to attach it to the soft-close activator – see illustration **d**. However, before fitting the soft-close activator to the adapter plate the two metal clips at either end of the soft-close activator need removing. This can be done by pushing the upright prongs apart slightly whilst at the same time sliding the clip towards the end of the activator – see illustration **d**.

Screw the adapter plate and the soft-close activator to the top track with the protruding metal lug of the soft-close activator pointing away from the wall end of the door.

See **Section 10** for instructions on how to set up the soft-close activators when they have been fitted to the top track.

### d) Steel top track

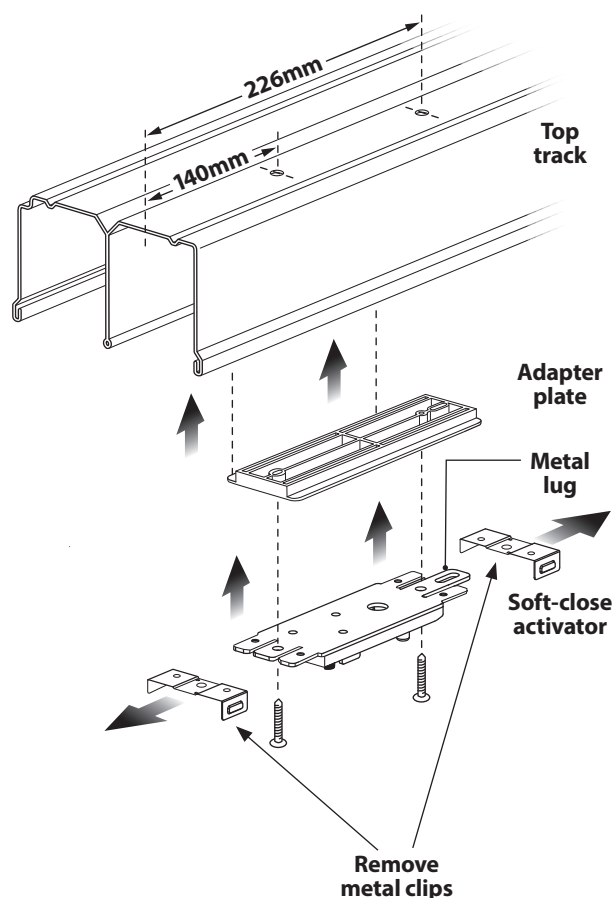

### 9.2.2 Aluminium top track

Using a 3mm diameter bit for drilling metal, drill **two holes** into the appropriate channel of the the top track, along its centre line. Measuring from the end of the track, the centre of the first hole should be at **140mm** and the centre of the second hole should be at **226mm** – see illustration **e**. Repeat this process for as many activators as you need to fit.

The soft-close activator should be located directly against the inside of the top track, with its pre-drilled holes matching the two you have made. Ensure the protruding metal lug is **pointing away** from the wall end of the door/track – see illustration **e**. Using a crosshead screwdriver, secure the soft-close activator to the top track.

See **Section 10** for instructions on how to set up the soft-close activators when they have been fitted to the top track.

### e) Aluminium top track

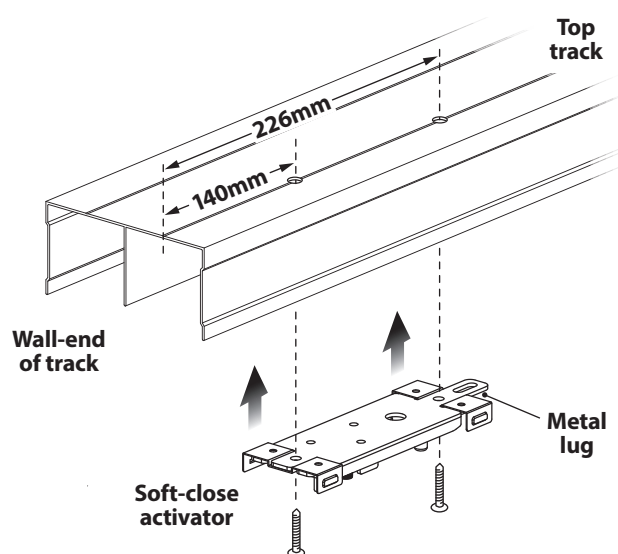

### 9.2.3 Minimalist aluminium top track

Using a 3mm diameter bit for drilling metal, drill two holes into the appropriate channel of the the top track, along its centre line – the first **120mm** from the end of the track and the second **206mm** from the end of the track – see illustration **f**. Repeat this process for as many activators as you need to fit. (If you are fitting soft-closers to doors which run in front and back channels you will need to fit activators into both channels.)

See **Section 10** for instructions on how to set up the soft-close activators when they have been fitted to the top track.

### 9.2.4 Shaker-style aluminium top track

Using a 3mm diameter bit for drilling metal, drill two holes into the appropriate channel of the the top track, along its centre line – the first **160mm** from the end of the track and the second **246mm** from the end of the track – see illustration **g**. Repeat this process for as many activators as you need to fit. (If you are fitting soft-closers to doors which run in front and back channels you will need to fit activators into both channels.)

See **Section 10** for instructions on how to set up the soft-close activators when they have been fitted to the top track.

### f) Minimalist aluminium top track

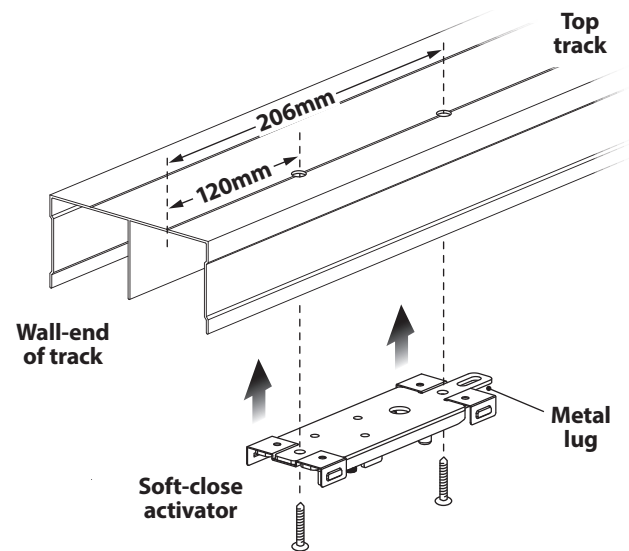

### g) Shaker-style aluminium top track

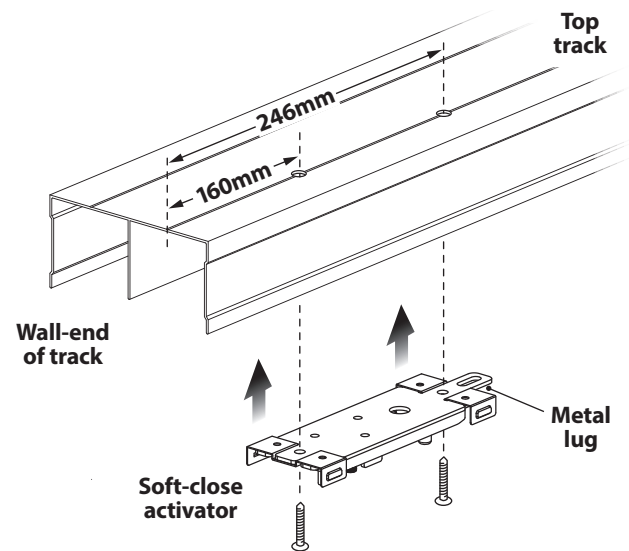

## 10. Setting up the soft-close activators

If it is already flush with the surface of the soft-close activator, flick the green plastic height indicator peg **up** so that it protrudes from the surface of the activator – see illustration **a**. The height indicator peg needs to be positioned so that it just touches the top of the soft-close mechanism (fitted to the top of the wardrobe door) and connects with the green plastic wheel protruding from the top surface of the mechanism when the door is slid towards it – see illustration **b**.

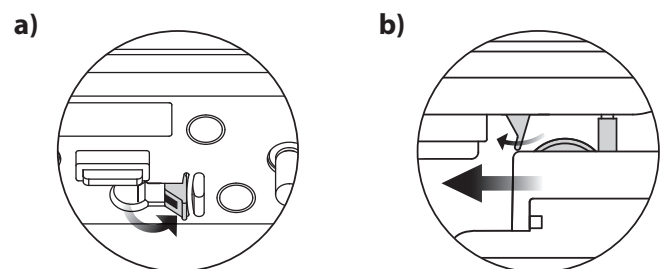

To achieve the correct position:

- either adjust the height of the door (see **section 7** on page 7) or;
- adjust the height of the soft-close activator using the screw thread and a 2.5mm diameter allen key – see illustration **c**.

The door is set to the correct height once you can close the door and you hear the audible 'click' of the height indicator peg being pushed closed. The soft-closer is now set up and should automatically soft-close the door when it is slid to this position.

Repeat the above steps to set up each soft-close activator that you have installed.

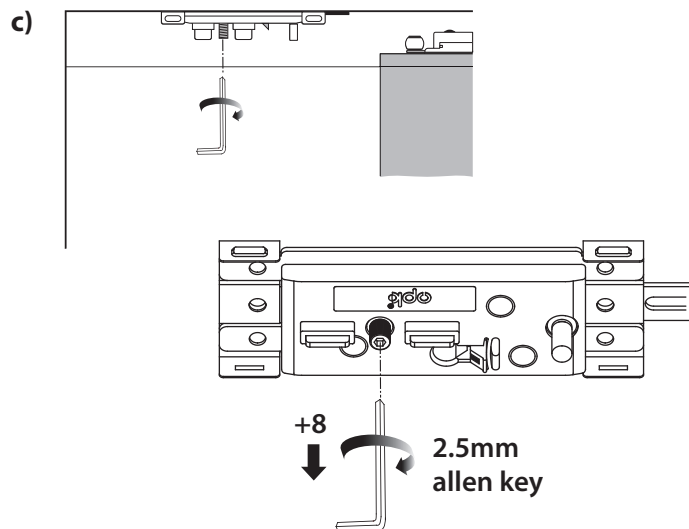

## 11. Applying the brush strips \*

If you have selected brush strips\*, a roll of soft brush strip will be provided with your order to apply to the closing edges of each door, enabling them to close silently against the strike plate and also to protect the stile edges. Simply cut the desired lengths from the roll to match the full height of your doors from top to bottom.

To fit, peel a short length (approx. 50mm) of backing paper away from one end of the brush strip and stick it to the top of the door stile at its centre point – see illustrations **a** and **b**. Align the length of the brush strip with the centre of the door stile from top to bottom; then peel away the remainder of the backing paper whilst at the same time carefully smoothing the adhesive strip against the door stile.

Repeat this process with all edges of the doors that will come into contact with a strike plate.

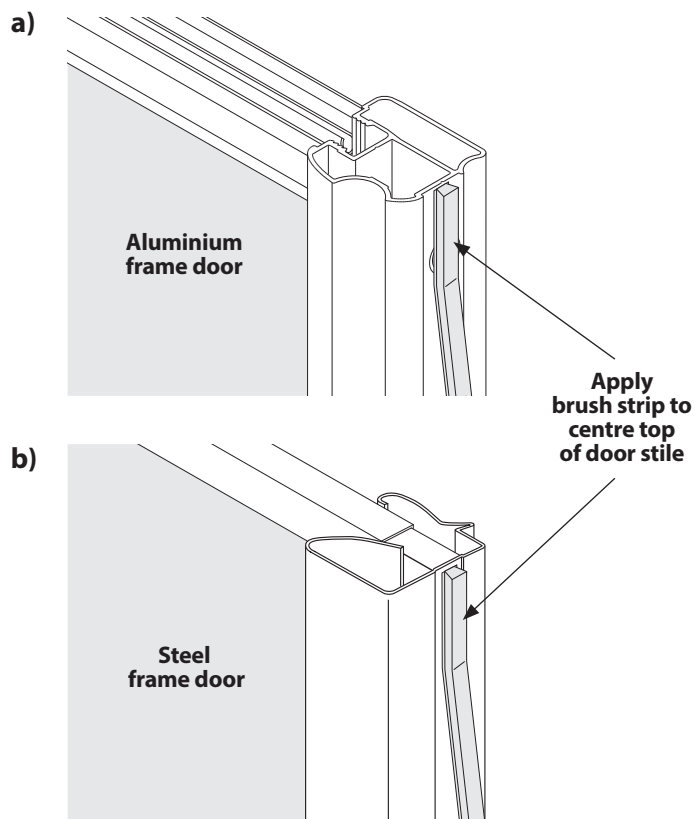

\* Please note, brush strips are optional extras that will need adding to your order.

## 12. Parts identifier

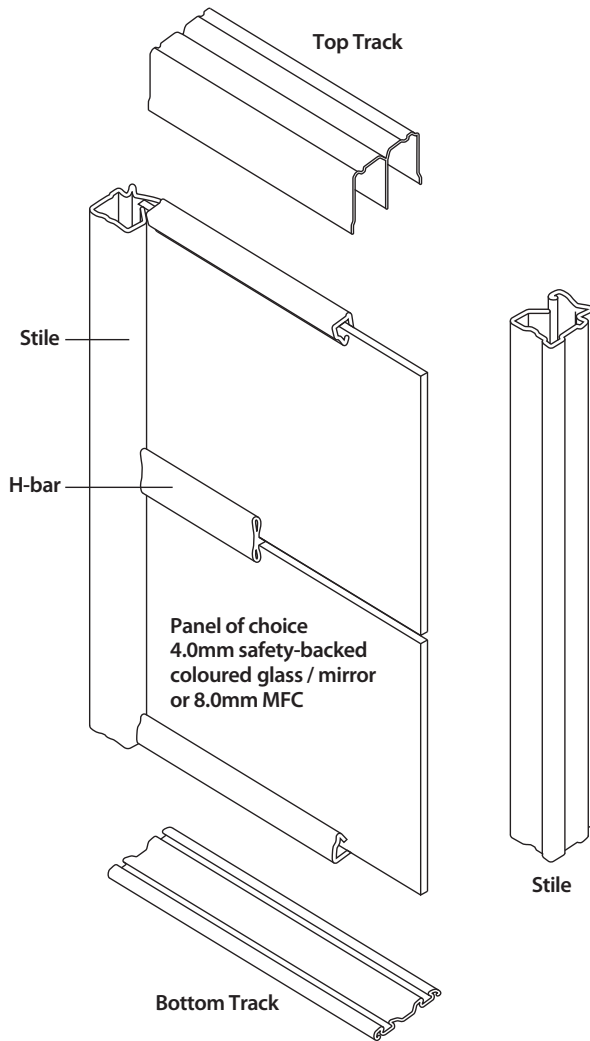

### SOFT-CLOSER MECHANISM\*

Comes pre-fitted to the top of each wardrobe door if you have specified soft-closing doors

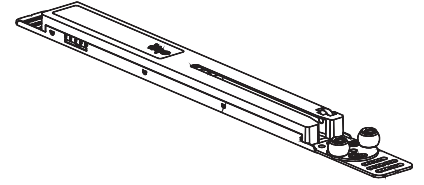

\*Soft closers are an optional extra and need adding to your order

### SOFT-CLOSE PACK\*

1 x soft-close activator per soft close mechanism fitted

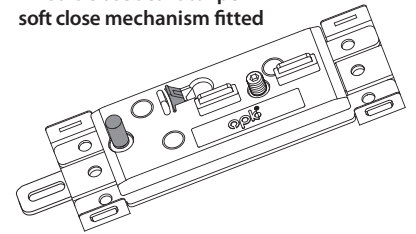

1 x adapter plate (steel frame only)

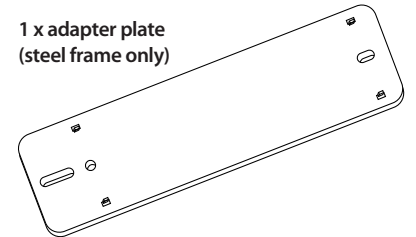

\*Soft closers are an optional extra and need adding to your order

### ALUMINIUM DOORS PACK

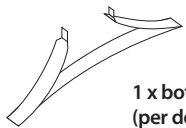

1 x bottom door positioner (per door)



1 x Allen key (per set)

### DOOR ROLLERS

#### STEEL

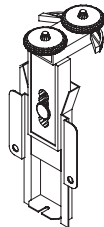

Top guide roller

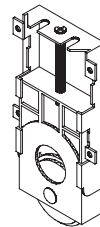

Adjustable bottom roller

#### ALUMINIUM

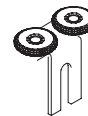

Top guide roller

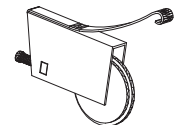

Adjustable bottom roller

Note: Items are not shown to the same scale

---

**WARDROBE**™  
DOORS DIRECT

The information provided herein is intended as a guide to good practice.  
Wardrobe Doors Direct cannot be held responsible or liable for any damage, wear or  
malfunction caused to components due to inadequate or improper installation.

**Wardrobe Doors Direct**  
Office: **6 Gawthorpe Avenue, Bingley, West Yorkshire BD16 4DG**  
Freephone: **0800 035 1730** Email: **info@wardrobedoorsdirect.co.uk**

**[www.wardrobedoorsdirect.co.uk](http://www.wardrobedoorsdirect.co.uk)**

Wardrobe Doors Direct is a trading style of Ichicoo Ltd.