

**PACK  
F**

# HIGH LEVEL SHELF WITH HANGING RAIL & CENTRE SUPPORT PANEL

## INSTALLATION GUIDE

This information sheet provides details of how to install an internal high level shelf with hanging rail and centre support panel. **Please take time to read it through fully prior to the installation of your sliding wardrobe doors.**

This pack contains:

- **Shelf**  
(l)1600/2000/2400mm x (w)450mm x (d)18 mm
- **2 x side shelf bearers**  
(l)430mm x (w)87mm x (d)18mm
- **1 x back shelf bearer**  
(l)1600 (2x790mm)/2000 (2x990mm)/2400mm  
x (2x1190mm) x (w)87mm x (d)18mm
- **Hanging rail**  
(l)1600/2000/2400mm
- **Centre support panel**  
(l)1750mm x (w)450mm
- **Fixings** - 5 x corner blocks; 16 x wallplugs; 16 x 40mm screws; 8 x 30mm screws; 4 x hanging rail brackets; 16 x 16mm screws; 4 x 10mm screws; self-adhesive screw head cover caps
- **Drilling template**

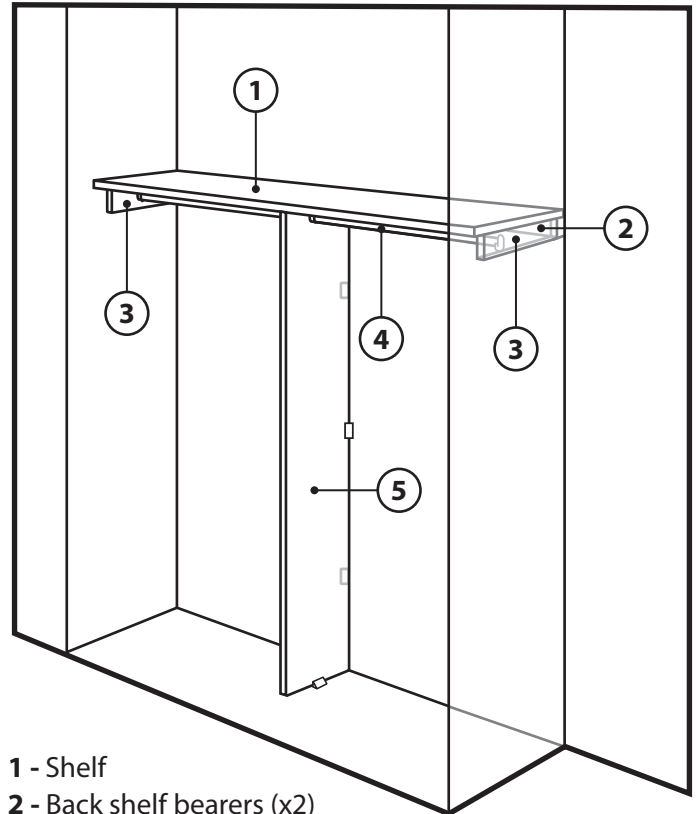

- 1 - Shelf
- 2 - Back shelf bearers (x2)
- 3 - Side shelf bearers
- 4 - Hanging rails (x2)
- 5 - Centre support/dividing panel

### Tools required (not supplied)

- Electric drill, 2mm diam. wood drill bit and 6mm diam. masonry drill bit
- Crosshead screwdriver
- Handsaw (with appropriate blade for cutting MFC)
- Hacksaw (32tpi blade recommended)
- Spirit level
- Bradawl
- Tape measure
- Pencil

## 1. Positioning the centre support panel

Measure the overall width of the area to be enclosed by the wardrobe and divide it by two to locate the centre point of the wall. At this point, using a spirit level, mark with a pencil a vertical line from the floor, up to a height of 1750mm. Position the centre support panel so that it is aligned centrally on the pencil line you have drawn and then, on each side of the panel, at the junction with the wall and floor, mark the position of the panel edges – see the diagram opposite.

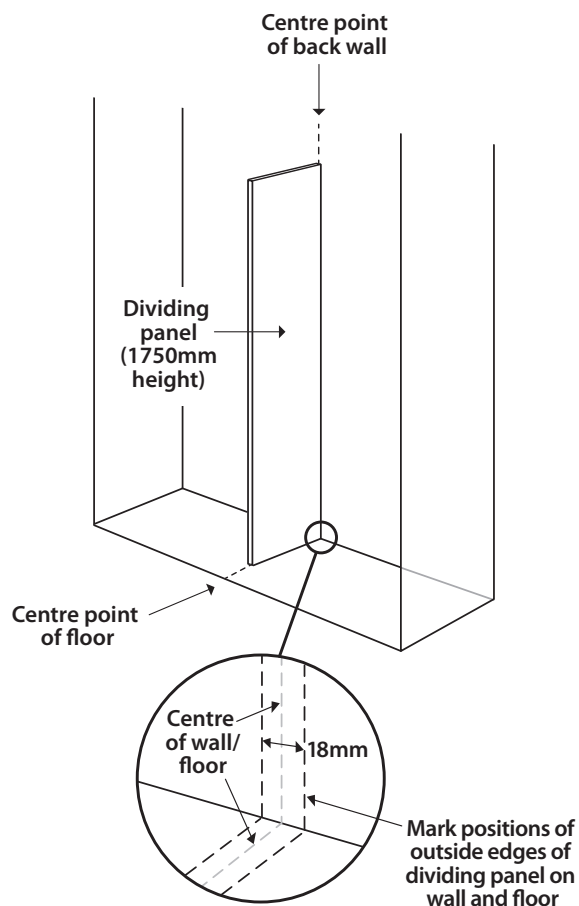

## 2. Fixing the centre support panel

Position three of the corner blocks on the back wall as shown in the diagram opposite.

Mark on the wall with a pencil the positions for drilling, drill the six holes and then insert the wallplugs. Screw the three corner blocks in place and slide the dividing panel so that it is held between them. Secure the dividing panel in place through the remaining holes in the corner blocks, using the 16mm screws. At the base of the dividing panel, position another corner block centrally, drill suitable pilot holes and secure it in place with 16mm screws. The remaining corner block will be positioned at the top centre of the dividing panel to secure it to the underside of the shelf, but this can only be done after the shelf has been fixed in place - see section 4.

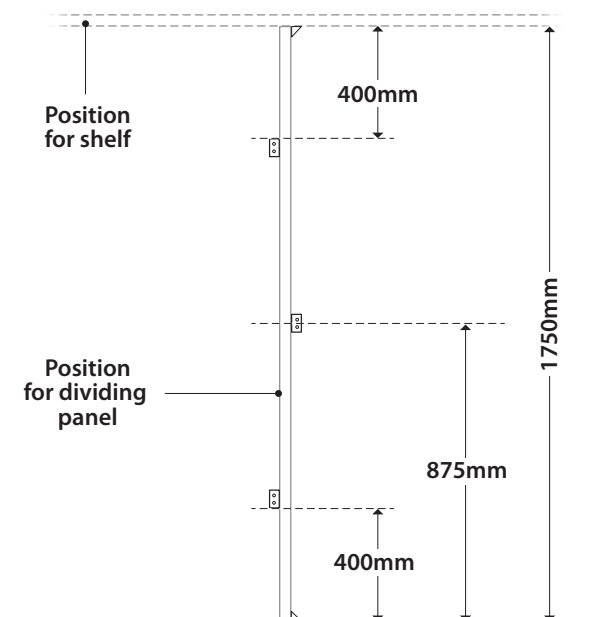

### 3. Fixing the shelf bearers

The shelf bearers should be positioned so that their tops are level with the top of the dividing panel (ie. at 1750mm height from the floor). Using a spirit level, draw a pencil line on the back and side walls at this height to indicate where the **underside** of the shelf will sit.

Identify the two back shelf bearers and cut them both to the length required by measuring the distance from the left hand wall to the dividing panel and from the dividing panel to the right hand wall.

**TIP** When cutting the shelf bearers (and the shelf) to length use masking tape along the cut lines to prevent the laminate surface from chipping. Carefully remove the tape after you have finished cutting.

On the two back and the two side shelf bearers, mark the position for drilling pilot holes for fixing the bearers to the back and side walls of the wardrobe – see the diagram opposite. We advise that the holes are counter sunk so once in place the self adhesive cover caps supplied will fit neatly over the screw heads.

Position one of the back shelf bearers against the back wall with its top edge level with the pencil line you have already marked. Using a bradawl through the pilot holes, mark the back wall with the positions for drilling the holes for the wallplugs. Remove the bearer and drill the holes in the back wall using a 6mm masonry drill bit. Push wallplugs firmly into the holes, offer up the shelf bearer again and secure it in place using the 40mm screws. Repeat this process to fix the other back shelf bearer and the two side shelf bearers in place.

Side Shelf Bearers

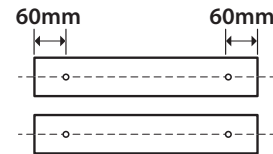

Back Shelf Bearers

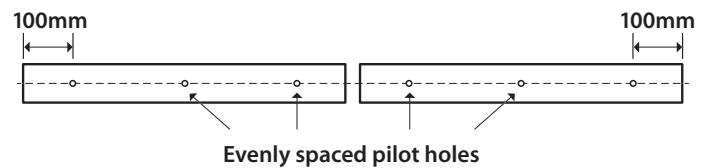

Drill pilot holes through the shelf bearers from each end at the distances shown. Depending upon their overall lengths, evenly space two or four additional pilot holes along the length of the back shelf bearers, after they have been cut to the required length.

### 4. Fixing the shelf

Measure the internal width of your wardrobe and cut the shelf to the same length. Prior to sliding the shelf into position, we recommend drilling and countersinking pilot holes through the sides and back edge of the shelf to enable it to be screwed to the side and back shelf bearers. Pilot holes can also be drilled and countersunk along the centre line of the shelf if it is to be screwed to the top of the centre dividing panel for added rigidity – see the diagram opposite.

Once the pilot holes have been drilled, slide the shelf into position and ensure that it is sitting firmly on all three shelf bearers and the top of the centre dividing panel. Screw the shelf to the shelf bearers (and dividing panel) using the 30mm screws provided. Finally, screw the top corner block in place after drilling suitable pilot holes.

Drill and countersink 2mm pilot holes through the top of the shelf at the positions shown

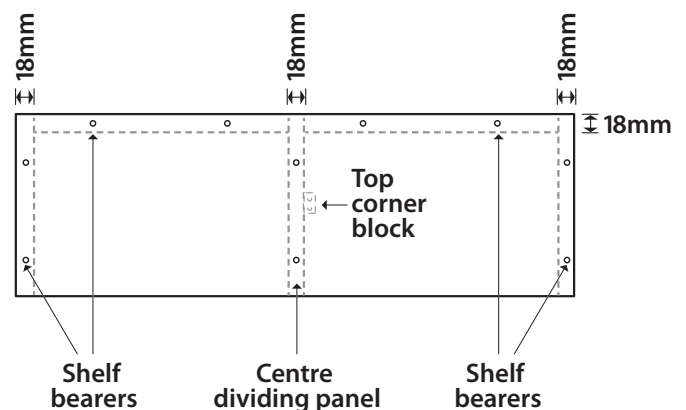

## 5. Fixing the hanging rails

To ensure the two hanging rails are positioned correctly, use the paper drilling template supplied. See the **diagrams 1 to 4** to help you position the drilling template correctly for each end of the hanging rails.

**TIP** You may wish to mark the positions for the pilot holes with a bradawl, remove the template and then drill the holes; rather than drilling the pilot holes directly through the paper template.

**When drilling the pilot holes in the centre dividing panel, take care not to drill completely through the panel.**

Once the pilot holes are drilled, place the hanging rail brackets in position (ensuring the U-shaped cup is at the bottom) and screw each one in place through the top and bottom holes. Use the 16mm screws to secure the brackets into the left and right shelf bearers; use the 10mm screws to secure the brackets into each side of the centre dividing panel.

Measure the distance between the inside faces of the hanging rail brackets in each side of the wardrobe and cut each of the two hanging rails to these lengths. The hanging rails can then be placed in position and should sit securely in the U-shaped cups of the brackets.

### 1. Drilling template position for hanging rail bracket on right hand shelf bearer

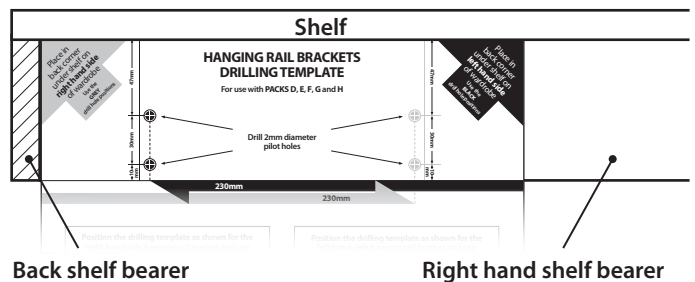

### 2. Drilling template position for hanging rail bracket on left hand shelf bearer

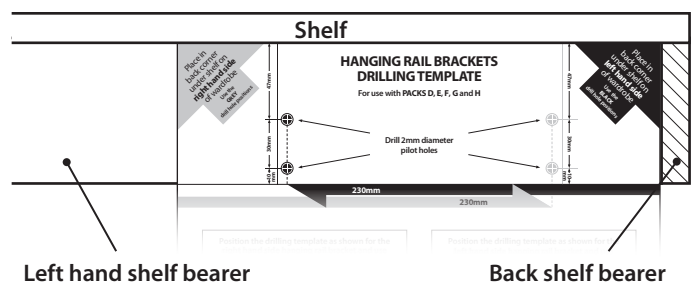

### 3. Drilling template position for hanging rail bracket on left hand side of centre dividing panel

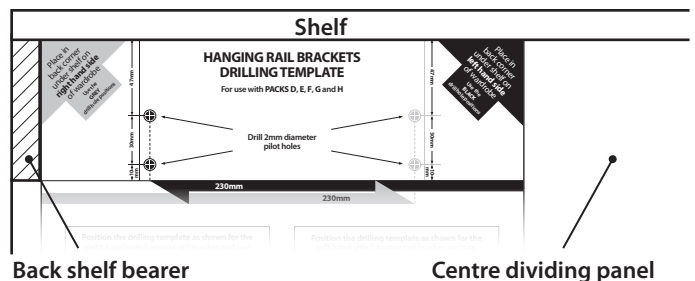

### 4. Drilling template position for hanging rail bracket on right hand side of centre dividing panel

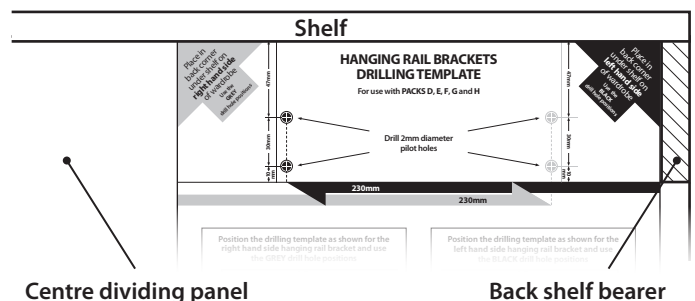

**Disclaimer:** It is the responsibility of the customer to ascertain that the area for installation is structurally sound and that any drilling necessary will not compromise electrical wiring, water pipes or gas services. The information provided herein is intended as a guide to good practice. The manufacturer cannot be held responsible or liable for any damage, wear or malfunction caused to components due to inadequate or improper installation.